

HORIZONTAL AXIS CONTINUOUS CENTRIFUGES TYPE EC



EC 06

KEY FEATURES OF EC CENTRIFUGES



EASE OF USE AND INSTALLATION

- Machine to be installed on a ground or mezzanine floor.
- Hinged casing for full opening and easy access to the basket.
- Separated feeding and washing pipes and outlets.
- Vibrator on casing for easier solid discharge..



PRODUCTIVITY

- Scroll type centrifuge.
- Continuous running particularly suitable for most continuous chemical processing lines.
- Wide application range:
 - G effect from 2000 to 2500.
 - Temperature from 0 to 200° C.
 - Solid particle size from 50 microns
- **High output up to 10 tons/hour.**



RELIABILITY

- Minimum vibration transmission due to centrifuge mass and heavy-duty antivibration pads.
- Torque limitation between basket and screw.

GENERAL DESIGN OF EC TYPE CENTRIFUGES

ROUSSELET ROBATEL Continuous Centrifugal Dehydrators are centrifuges with a filtering basket. They assure the separation, the eventual washing and the drying of a solid phase suspended into a liquid phase.

CONSTRUCTION

In mild steel, stainless steel or special alloys.

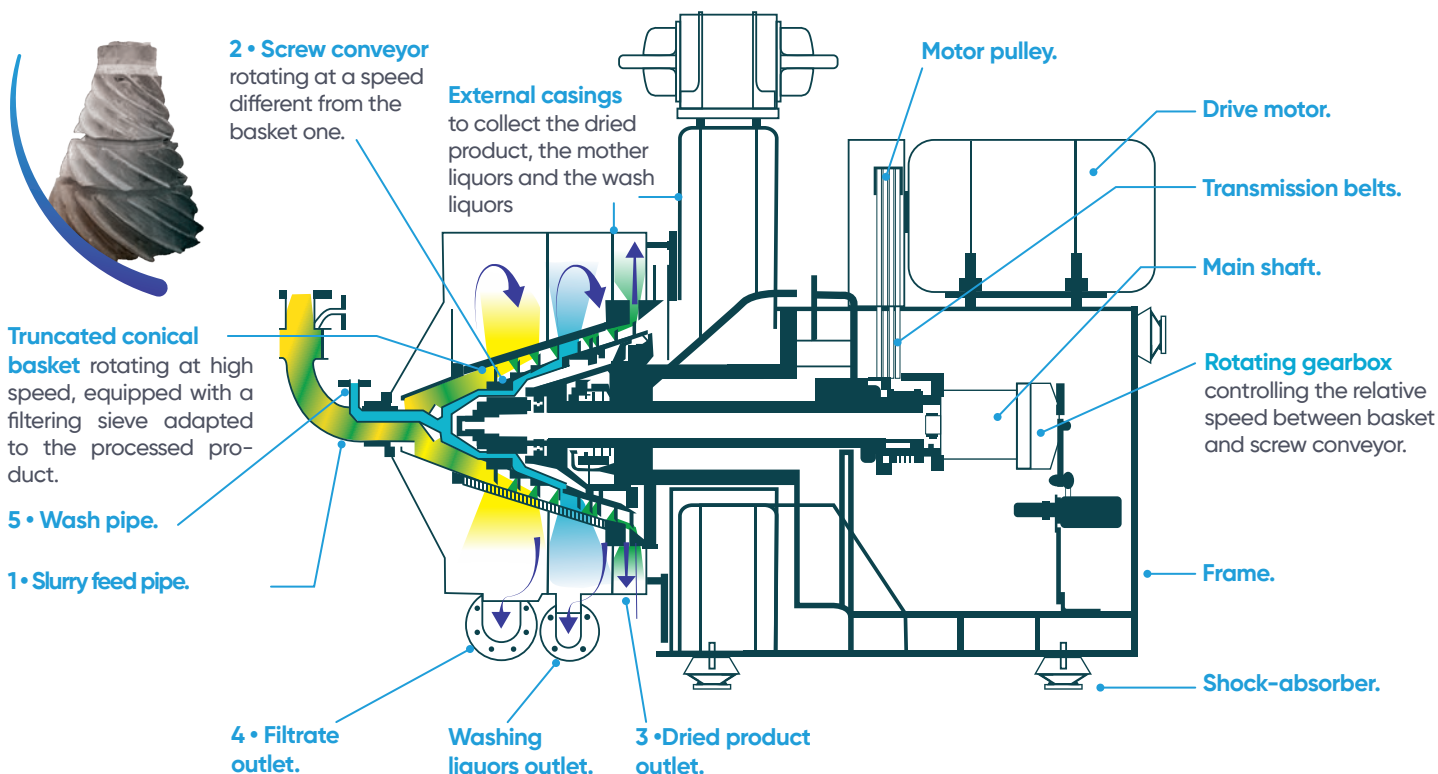

OPERATION

- The slurry to be processed is fed by gravity or by pump through feed pipe¹.
- Due to centrifugal force, the solid product is thrown against the inner wall of the basket.
- It is then continuously discharged by the screw conveyor² and discharged through outlet³.
- The filtrate liquid is discharged through outlet⁴.
- The wash pipe⁵ allows washing liquids feeding to rinse solids prior to final spinning before and discharging.

TECHNICAL CHARACTERISTICS

TYPE	Basket			Centrifuge			
	ø mm	Max speed rpm	Centrifugal force G	L cm	l cm	h cm	Weight kg
EC 03	300	3600	2560	170	130	150	1000
EC 04	400	2900	2250	210	150	175	2400
EC 06	600	2300	2300	250	200	190	4500

Autres modèles sur demande.



HEADQUARTERS

ROUSSELET ROBATEL
45 Avenue Rhin et Danube
Parc d'activité économique de Marenton
07104 ANNONAY - FRANCE
Tel.: +33 (0)4 75 69 22 11
E-mail: info@rousselet-robatel.com

UK

Rousselet UK Ltd
Parkside House, 17 East Parade
HARROGATE
NORTH YORKSHIRE HG1 5LF
Tel.: + 44 (0)1 423 530 093
E-mail: info@rousselet-robatel.com

DEUTSCHLAND

ARRGOS GmbH
Max-Eyth-Str. 1
D-71691 Freiberg a.N.
Tel : +49(0)7 7229 20
Fax : +0)173 757 6226
Email : nicolas.kiehl@arrgos.de

USA

Robatel Inc.
703 West Housatonic Street
PITTSFIELD
MA 01201
Tel: + 1 413 499 4818
E-mail: sales@rr-centrifuge.com